

A Perfect Match

Replacing your Central Air Conditioning or Heat Pump System

You're about to make an important investment in your home — one that will affect your comfort for years to come. That's why it's important to have all the facts...

Split air conditioning and heat pump systems typically consist of two parts: an indoor (coil) unit and an outdoor (condensing) unit. These two parts are specifically designed to work together as a coordinated "team" to provide top performance and maximum efficiency and comfort. So if you install a new high-efficiency outdoor unit, but don't include a new, equally efficient and properly matched indoor unit, the results could be uncomfortable, frustrating and expensive.

Why a Perfect Match is Important

Simply replacing just one of your cooling system's units may offer you the lowest price, but it won't give you the best value. At best, the system may still operate, but it won't perform up to the promised energy efficiency level and provide you with the level of comfort cooling you expect.



At worst, improperly matched indoor and outdoor units can create undue stress on your cooling system, resulting in an unnecessary, premature failure.

If you choose a new system using a non-ozone depleting hydrofluorocarbon (HFC) refrigerant, you must replace your indoor and outdoor units with a properly matched combination designed to work using this refrigerant. If you do not change both units, your system will prematurely fail.

When you consider the costs of repairing or replacing an air conditioner or heat pump, installing a properly matched system the first time around makes good sense. Of course, replacing the indoor coil will add to the cost of installation, but it will mean greater comfort and energy savings in the long run.

Ask for a Certificate of ARI Certified Performance



A qualified contractor will verify the system being installed is properly matched and achieves a certified energy efficiency rating by providing you with an ARI Reference Number, or a Certificate of ARI Certified Performance. An ARI Reference Number can be found by accessing ARI's free online Directory of Certified Product Performance at www.aridirectory.org.



To find a qualified contractor, look for one who is licensed, well-trained and experienced. Search for companies employing technicians certified by North American Technician Excellence (NATE) (www.natex.org).

Obtain Utility Rebates

Qualifying for a utility rebate for installing a high-efficiency system in your home is one more good reason to make sure it is an ARI Performance Certified™ matched system. Check with your local utility company for its rebate rules, but many require you to provide your system's ARI Reference Number to claim a rebate. This number can be provided to you by your installer.

How Split Air Conditioning Systems Work

Contrary to what many people believe, an air conditioner does not add cool air to an area, but instead removes heat from the air to make it cooler. The engineering marvel of cooling is accomplished by the use of a working fluid known as a refrigerant, and four main mechanical parts:

1. A condenser
2. A compressor
3. An evaporator coil
4. Air handler/furnace

The condenser and compressor are located outside the home in a large metal cabinet called the condensing unit. The evaporator coil is located inside the home typically above or near the air handling unit (furnace or blower). The inside components may be located in a crawlspace, basement, attic or closet.

The refrigerant flows from the outdoor unit to the indoor unit through **copper tubing (5)**. Inside, refrigerant flows into the evaporator coil where it absorbs heat. The refrigerant then moves this absorbed heat to the outdoor unit where the compressor squeezes the refrigerant. The heat that was absorbed by the refrigerant is released from the outside condenser coil and carried away by outdoor air.

The cycle continues until the room reaches a set temperature on a **thermostat (6)**. When the thermostat senses that the room has reached the set temperature, it turns off the air conditioner. As the room warms up, the thermostat turns the air conditioner back on.

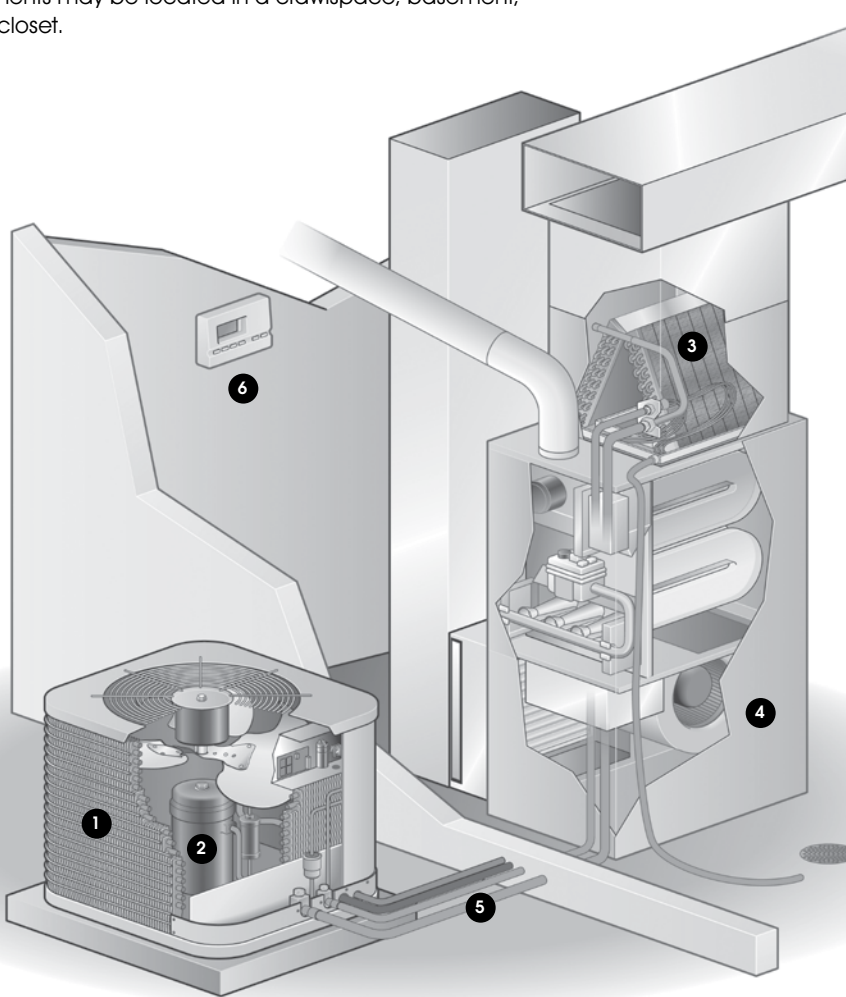

Ensuring Efficiency

The efficiency of a central air conditioner is rated by its Seasonal Energy Efficiency Ratio (SEER). This SEER rating is technically defined as the cooling output provided by the air conditioner or heat pump during its normal annual usage period, divided by its total energy consumption. Similar to the miles-per-gallon rating for automobiles, the higher a central cooling system's SEER rating, the more efficient it is because it requires less electricity to cool your home. As of 2006, all newly manufactured central air conditioners and heat pumps must achieve a minimum SEER of 13.

Learn More About Comfort Cooling

Visit ARI's Web site at www.ari.org and learn about indoor comfort systems, proper maintenance, saving energy and how to find certified technicians.



Air-Conditioning
and Refrigeration
Institute

*Improving Life and
the Environment*

4100 North Fairfax Drive, Suite 200
Arlington, VA 22203-1678, USA

PH 703.524.8800
FX 703.528.3816

www.ari.org